

**CBSE**  
**Class XII Physics**  
**Sample Paper 1**

**Time: 3 Hours**

**Maximum Marks: 70**

**General Instructions:**

1. All questions are compulsory. There are 33 questions in all.
2. This question paper has five sections: Section A, Section B, Section C, Section D and Section E.
3. Section A contains ten very short answer questions and four assertion reasoning MCQs of 1 mark each, Section B has two case based questions of 4 marks each, Section C contains nine short answer questions of 2 marks each, Section D contains five short answer questions of 3 marks each and Section E contains three long answer questions of 5 marks each.
4. There is no overall choice. However internal choice is provided. You have to attempt only one of the choices in such questions
5. You may use the following values of physical constants wherever necessary.

$$c = 3 \times 10^8 \text{ m / s}$$

$$h = 6.63 \times 10^{-34} \text{ Js}$$

$$e = 1.6 \times 10^{-19} \text{ C}$$

$$\mu_0 = 4\pi \times 10^{-7} \text{ T m A}^{-1}$$

$$\epsilon_0 = 8.854 \times 10^{-12} \text{ C}^2 \text{ N}^{-1} \text{ m}^{-2}$$

$$\frac{1}{4\pi\epsilon_0} = 9 \times 10^9 \text{ N m}^2 \text{ C}^{-2}$$

$$m_e = 9.1 \times 10^{-31} \text{ kg}$$

$$\text{mass of neutron} = 1.675 \times 10^{-27} \text{ kg}$$

$$\text{mass of proton} = 1.673 \times 10^{-27} \text{ kg}$$

$$\text{Avogadro's number} = 6.023 \times 10^{23} \text{ per gram mole}$$

$$\text{Boltzmann constant} = 1.38 \times 10^{-23} \text{ JK}^{-1}$$

**Section A**

1. A proton projected towards the east is deflected towards the north by a magnetic field. The field is in which direction? (1)

**OR**

Identify which among the parallel and anti-parallel currents shows attraction and repulsion?



2. Out of Proton, electron  $\text{He}^+$  and  $\text{Li}^+$  Identify the particle which has minimum frequency of revolution when projected perpendicular to the magnetic field with the same velocity. (1)

3. What kind of phenomenon is light: wave, particle or both? (1)

**OR**

Which among the following is true for a total internal reflection.

Light travels from rarer to denser medium or Light travels from denser to rarer medium.

4. Coherent sources are used to produce waves of\_\_\_\_\_. (1)

**OR**

How much phase difference does a light wave suffers on reflection from a denser medium.

5. What is the relation between  $n_p$  and  $n_e$  in intrinsic semiconductor. (1)

6. What is the direction of drift current in a p-n junction. (1)

**OR**

What is name of the region without free electrons and holes in a p-n junction?

7. Wavelength is minimum for which of the following transitions? (1)

(a)  $n=5$  to  $n=4$

(b)  $n=4$  to  $n=3$

(c)  $n=3$  to  $n=2$

(d)  $n=2$  to  $n=1$

8. What is the general formula for orbital angular momentum of the electron in a hydrogen atom? (1)

9. What would be the net electric force on the dipole in a uniform electric field? (1)

10. What would happen to the electric potential energy of the charges if the distance between two charges increases? (1)

**For question numbers 11, 12, 13 and 14, two statements are given-onelabelled Assertion (A) and the other labelled Reason (R). Select thecorrect answer to these questions from the codes (a), (b), (c) and (d)as given below.**

**(a) Both A and R are true and R is the correct explanation of A**

**(b) Both A and R are true but R is NOT the correct explanation of A**

**(c) A is true but R is false**

**(d) A is false and R is also false**



11. Assertion: The resistivity of a semiconductor increases with temperature.  
Reason: At higher temperature atoms start vibrating at higher amplitude and hence its resistivity increases. (1)
12. Assertion: Energy of the electron hydrogen atom in first excited state is  $-3.4\text{eV}$   
Reason: Energy of electron of hydrogen atom in  $n$ th orbit is given by  $E = -13.6/n^2$  (1)
13. Assertion: Light shows the phenomenon of interference, diffraction and Polarisation.  
Reason: Because of particle nature of light (1)
14. Assertion: Conductors having equal positive charge and volume, must also have same potential. (1)  
Reason : Potential depends only on charge and volume of conductor.

## Section B

**Questions 15 and 16 are Case Study based questions and are compulsory. Attempt any 4 sub parts from each question. Each question carries 1 mark.**

15. Coulomb measured the force between two point charges and found that it varied inversely as the square of the distance between the charges and was directly proportional to the product of the magnitude of the two charges and acted along the line joining the two charges. Thus, if two point charges  $q_1, q_2$  are separated by a distance  $r$  in vacuum, the magnitude of the force ( $F$ ) between them is given by  $F = \frac{kq_1q_2}{r^2}$ . Consider three charges  $q_1, q_2, q_3$  each equal to  $q$  at the vertices of an equilateral triangle of side  $l$ . A charge of magnitude  $Q$  and polarity same as other charges is placed at the centroid of the triangle. (4)

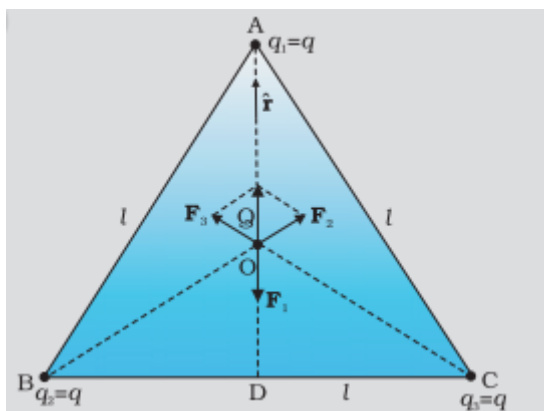

- a) Force exerted on  $Q$  by each charge present on the vertices of the triangle
- i. Zero
  - ii. Equal
  - iii.  $F_A > F_B > F_C$
  - iv.  $F_A < F_B < F_C$
- b) The magnitude of Force on  $Q$  by charge  $q$  present on  $A$  is

i.  $F = \frac{kqQ}{l^2}$

ii.  $F = \frac{kqQ}{\left(\frac{l}{\sqrt{3}}\right)^2}$

iii.  $F = \frac{kqQ}{\left(\frac{l}{2}\right)^2}$

iv.  $F = \frac{kqQ}{\left(\frac{2l}{3}\right)^2}$

c) The magnitude and direction of force experienced by the charge Q due the charge present on the vertex C of the triangle

i. Zero

ii.  $F = \frac{kqQ}{\left(\frac{l}{\sqrt{3}}\right)^2}$  Along CO

iii.  $F = \frac{3kqQ}{l^2}$  Along CO

iv.  $F = \frac{kqQ}{\left(\frac{2l}{3}\right)^2}$  Along CO

d) What would be the direction of the Force experienced by the charge q present on vertex A of the triangle due to all other charges.

i. upwards

ii. downwards

iii. left

iv. Right

e) What would be the Resultant force on Q if the polarity of charges present on the vertices in opposite to that of Q

i. Zero

ii.  $F_R = \frac{-3kqQ}{\left(\frac{l}{\sqrt{3}}\right)^2}$

iii.  $F_R = \frac{-kqQ}{\left(\frac{l}{2}\right)^2}$

iv.  $F_R = \frac{-kqQ}{\left(\frac{2l}{3}\right)^2}$

16.

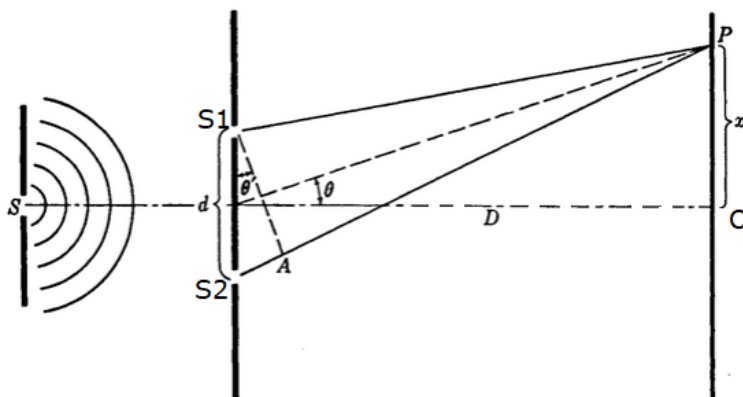

In Young's double slit experiment A monochromatic light is passed through a single narrow slit and falls on S1 and S2. These two slits act as sources of light waves that interfere constructively and destructively at different points on the screen to produce a pattern of alternating bright and dark fringes. For constructive interference  $x_n = \frac{n\lambda D}{d}$

whereas for destructive interference  $x_n = (2n+1) \frac{\lambda D}{2d}$ . What is the effect on the interference fringes in a Young's double-slit experiment due to each of the following operations (4)

- a) When the screen is moved away from the plane of the slits
  - i. Separation of fringes increases.
  - ii. Separation of fringes decreases.
  - iii. Separation of fringes remains constant.
  - iv. None of these
- b) When the (monochromatic) source is replaced by another (monochromatic) source of shorter wavelength
  - i. Separation of fringes increases.
  - ii. Separation of fringes decreases.
  - iii. Separation of fringes remains constant.
  - iv. None of these
- c) When the separation between the two slits is increased
  - i. Separation of fringes increases.
  - ii. Separation of fringes decreases.
  - iii. Separation of fringes remains constant.
  - iv. None of these
- d) When the source slit is moved closer to the double-slit plane
  - i. Separation of fringes increases
  - ii. Separation of fringes decreases.
  - iii. Separation of fringes remains constant
  - iv. None of these
- e) When the width of the source slit is increased



- i. Separation of fringes increases
- ii. Separation of fringes decreases
- iii. Separation of fringes remains constant
- iv. None of these

### Section C

**All questions are compulsory. In case of internal choices, attempt anyone.**

17. An electron, alpha particle and proton have the same kinetic energy. Which of these particles has the shortest de Broglie wavelength? (2)
18. Is it correct to say that a potentiometer is equivalent to an ideal voltmeter? Explain Why? (2)

**OR**

The resistance of a platinum wire of a resistance at ice point is 5 ohm and at steam point is 5.23 ohm. When the thermometer is inserted in a hot bath, the resistance of the platinum wire is 5.795 ohms. Calculate the temperature of the bath.

19. What type of a charge is present on an n-type semiconductor? Why? (2)
20. Why are sky waves not used for transmission of TV signals? State two factors which can increase the range of transmission. (2)
21. State the conditions under which Ohm's law is not obeyed by a conductor. (2)

**OR**

A battery has an emf of 12 V. If the internal resistance of the battery is 0.4 ohm, what is the maximum current that can be drawn from the battery?

22. Find the maximum frequency and minimum wavelength of X-rays produced by 30keV electrons. (2)
23. Calculate the length of a half-wave dipole antenna at
- i. 30 MHz
  - ii. 300 MHz
- What inference do you draw from these results? (2)
24. A proton and an electron have same kinetic energy. Which one has greater de-Broglie wavelength and why? (2)
25. How is forward biasing different from reverse biasing in a p-n junction diode?

**OR**

Draw energy band diagram of n-type and p-type semiconductor at temperature  $T > 0K$ . Mark the donor and acceptor energy level with their energies (2)



## Section D

All questions are compulsory. In case of internal choices, attempt any one.

26.

- Electron drift arises due to the force experienced by electrons in the electric field inside a conductor. A force causes acceleration in accordance with Newton's second law. Why then do the electrons acquire a steady average drift speed but no acceleration?
- What is the path of electrons along a straight line between successive collisions in the presence of an electric field? (3)

27. With the help of a labelled diagram, briefly describe the construction of a coaxial cable. What is the upper limit of frequency up to which a coaxial cable can be used? (3)

28. Two devices A and B are connected independently to a variable frequency alternating voltage source. The current in A leads the applied voltage, whereas the current in B lags the applied voltage.

- Identify the circuit elements A and B.
- How will the current in these circuit elements change if the applied frequency is decreased? (3)

OR

An AC voltage  $E = E_0 \sin \omega t$  is applied across a pure inductor of inductance  $L$ . Show mathematically that the current flowing through it lags behind the applied voltage by a phase angle of  $\pi / 2$ . (3)

29. Briefly explain the principle of the working of an AC generator. What is the maximum emf produced by it?

OR

When primary coil P is moved towards secondary coil S (as shown in the figure below), the galvanometer shows momentary deflection. What can be done to have larger deflection in the galvanometer with the same battery? (3)

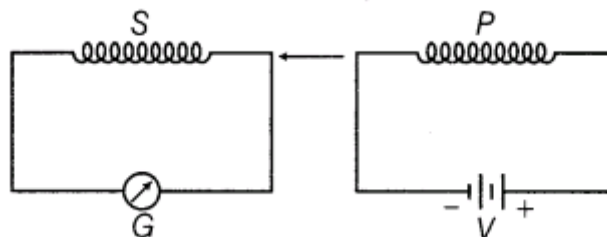

30. State five important characteristics of photons. (3)

## Section E

**All questions are compulsory. In case of internal choices, attempt any one.**

- 31.** State the essential condition for diffraction of light to take place. Use Huygen's principle to explain diffraction of light due to a narrow single slit and the formation of a pattern of fringes obtained on the screen. Sketch the pattern of fringes formed due to diffraction at a single slit showing variation of intensity with angle  $\theta$ . (5)

**OR**

What are coherent sources of light? Why are coherent sources required to obtain a sustained interference pattern?

State three characteristic features which distinguish the interference pattern due to two coherently illuminated sources as compared to that observed in a diffraction pattern due to a single slit. (5)

- 32.** State Biot-Savart law. Use it to obtain the magnetic field at an axial point at a distance  $x$  from the centre of a circular coil of radius carrying a current  $I$ . Compare the magnitude of the magnetic field at the centre of the coil and at an axial point for which  $x = \sqrt{3}a$ . (5)

**OR**

- A) Figure shows a rectangular loop conducting PQRS in which the arm PQ is free to move. A uniform magnetic field acts in the direction perpendicular to the plane of the loop. Arm PQ is moved with a velocity  $v$  towards the arm RS. Assuming that the arms QR, RS and SP have negligible resistances and the moving arm PQ has the resistance  $r$ , obtain the expression for

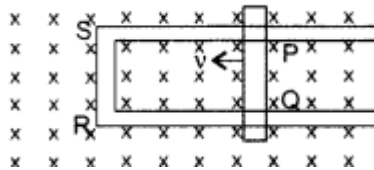

- (i) the current in the loop
  - (ii) the force and
  - (iii) the power required to move the arm PQ.
- B) A rectangular loop of wire of size 2 cm × 5 cm carries a steady current of 1 A. A straight long wire carrying 4 A current is kept near the loop as shown in the figure. If the loop and the wire are coplanar, find

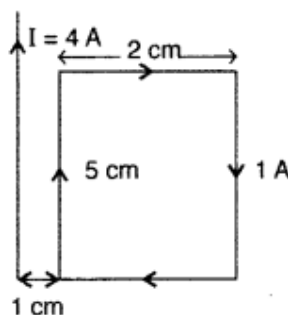



- (i) the torque acting on the loop and
- (ii) the magnitude and direction of the force on the loop due to the current carrying wire.

**33.** A transistor is used in the common emitter mode in an amplifier circuit. When a signal of 20 mV is added to the base-emitter voltage, the base current changes by  $20 \mu A$  and the collector current changes by 2 mA. The load resistance is  $5 k \Omega$ . Calculate (a) factor  $\beta$ , (b) input resistance  $R_{BE}$ , (c) transconductance and (d) voltage gain. (5)

**OR**

With the help of a labelled circuit diagram, describe the working principle of a common emitter amplifier using a  $p-n-p$  transistor. Define the terms current gain and voltage gain and write their expressions.

**CBSE**  
**Class XII Physics**  
**Sample Paper1– Solution**

---

**Section A**

1. Downwards.

The force is given by  $\vec{F} = q \vec{v} \times \vec{B}$ .

**OR**

parallel currents attract and anti parallel currents repel.

2.  $\text{Li}^+$

3. Both wave and particle phenomena

**OR**

Light travels from denser to rarer medium.

4. Constant phase difference

**OR**

$\pi$

5.  $n_p = n_e$

6. From nside to pside

**OR**

depletion region

7. (d)  $n=2$  to  $n=1$ .

For this transition, energy change is maximum and  $E \propto \frac{1}{\lambda}$ .

- 8.

$$\frac{nh}{2\pi}$$

9. Zero

As both charges are equal in magnitude but opposite in polarity.

10. May increase or decrease

It depends on the polarity of charges. In case of same polarity, potential energy decreases with separation, whereas in case of opposite polarity, it increases with separation.



11. D : Assertion is false and Reason is also false

As the temperature increases, energy exchange increases causing more valence electron to cross the energy gap and hence increasing the electron- hole pair. In semiconductor the conduction mainly occurs due to electron -hole pairs, therefore conductivity increases with increase in temperature and resistivity decreases with increase in temperature.

12. A: Both Assertion and Reason are true and R is the correct explanation of A

$$E = \frac{-13.6}{n^2}$$

$$E = \frac{-13.6}{2^2}$$

$$E = -3.4 \text{ eV}$$

13. c)A is true but R is false

Light shows the phenomenon of interference, diffraction and Polarisation because of the wave nature of light.

14. D) Assertion is false and Reason is also false:

Electric potential of a charged conductor depends not only on the amount of charge and volume but also on the shape of the conductor. Hence if their shapes are different, they may have different electric potential.

## Section B

15.

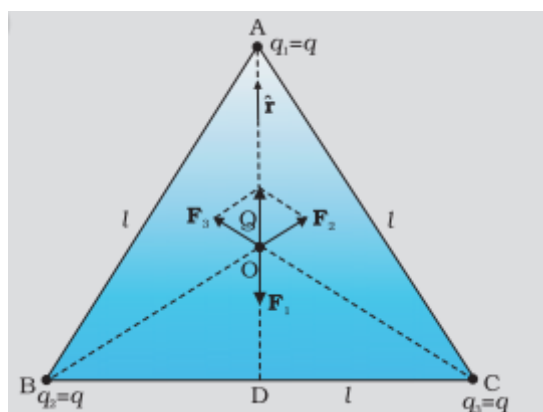

a) i. Zero. As Q is present on the centroid hence the force exerted by all the charges are equal and due to symmetry the force will cancel out each other and the resultant force would become zero.

b) ii.  $F_r = \frac{kqQ}{\left(\frac{1}{\sqrt{3}}\right)^2}$ . The distance between A and O is  $\frac{2}{3}(AD) \Rightarrow \frac{2}{3}\left(\frac{\sqrt{3}}{2}l\right) \Rightarrow \frac{l}{\sqrt{3}}$

c) ii. The magnitude and direction of force experienced by the charge Q due the charge present on the vertex C of the triangle is  $F = \frac{kqQ}{\left(\frac{1}{\sqrt{3}}\right)^2}$  Along CO

d) i. Upwards.

e) i. Zero. As Q is present on the centroid hence the force exerted by all the charges are equal and due to symmetry the force will cancel out each other and the resultant force would become zero.

16. a) i. Separation of fringes increases.

b) ii. Separation of fringes decreases.

c) ii. Separation of fringes decreases.

d) iii. Separation of fringes remains constant. Thus, as S decreases (i.e., the source slit is brought closer), the interference pattern gets less and less sharp, and when the source is brought too close for this condition to be valid, the fringes disappear. Till this happens, the fringe separation remains fixed.

e) iii. Separation of fringes remain constant. Same as in (d). As the source slit width increases, fringe pattern gets less and less sharp. When the source slit is so wide that the condition  $s/S \leq \lambda/d$  is not satisfied, the interference pattern disappears.

## Section C

17. de Broglie wavelength:

$$\lambda = \frac{h}{p} = \frac{h}{\sqrt{2mK}}$$

For the same kinetic energy, de Broglie wavelength depends on the mass of the particle.

As the alpha particle is the most massive of the three, its de Broglie wavelength will be the shortest.

18. Yes, because the potentiometer does not draw any current from the circuit, but it still measures the potential difference.

An ideal voltmeter has infinite resistance, and hence, it does not draw any current from the circuit.

OR

$$R_0 = 5 \Omega \quad R_{100} = 5.23 \Omega \quad \text{and} \quad R_t = 5.795 \Omega$$



$$t = \frac{R_t - R_0}{R_{100} - R_0} \times 100$$

$$t = \frac{5.795 - 5}{5.23 - 5} \times 100$$

$$t = \frac{0.795}{0.23} \times 100 = 345.65 \text{ } ^\circ\text{C}$$

19. The n-type semiconductor is neutral, i.e. uncharged, because the atoms of every substance are neutral. The pentavalent impurity atoms are neutral even though their electronic structure provides excess of electrons when mixed in a pure semiconductor.
20. TV signals have a frequency between 100 and 200 MHz, so they are not reflected by the ionosphere. Thus, their transmission via sky waves is not possible. The range can be increased by using (i) taller antenna and (ii) geostationary satellites.
21. Ohm's law is not obeyed when the  
 (i) Temperature is not constant.  
 (ii) Conductor is not ohmic.

OR

$$I_{\text{max}} = \frac{E}{r}$$

$$E = 12 \text{ V and } r = 0.4 \text{ } \Omega$$

$$\therefore I_{\text{max}} = \frac{12}{0.4} = 30 \text{ A}$$

22. Energy of electrons

$$E = 30 \text{ keV} = 30 \times 10^3 \times 1.6 \times 10^{-19} \text{ joule}$$

From Einstein equation,

$$E = h\nu$$

$$\nu = \frac{E}{h} = \frac{30 \times 10^3 \times 1.6 \times 10^{-19}}{6.6 \times 10^{-34}} = 7.27 \times 10^{18} \text{ Hz (1)}$$

$$\lambda = \frac{v}{\nu} = \frac{c}{\nu} = \frac{3.0 \times 10^8}{7.27 \times 10^{18}} = 0.0413 \text{ nm (1)}$$

23. (a)  $\nu = 30 \text{ MHz} = 30 \times 10^6 \text{ Hz}$

$$\lambda = \frac{c}{\nu} = \frac{3 \times 10^8}{30 \times 10^6} = 10 \text{ m}$$

$$l = \frac{\lambda}{2} = \frac{10}{2} = 5 \text{ m}$$

(b)  $\nu = 300 \text{ MHz} = 3 \times 10^8 \text{ Hz}$

$$\lambda = \frac{c}{\nu} = \frac{3 \times 10^8}{3 \times 10^8} = 1 \text{ m}$$

$$l = \frac{\lambda}{2} = \frac{1}{2} = 0.5 \text{ m}$$

Thus, we observe that the length of the dipole antenna decreases as the frequency of transmission increases.

24.

Kinetic energy of a particle  $E = \frac{1}{2} m v^2$

$$m v = \sqrt{2 m E}$$

de-broglie wavelength associated with the particle is

$$\lambda = \frac{h}{m v} = \frac{h}{\sqrt{2 m E}}$$

For a given value of E,  $\lambda = \frac{h}{\sqrt{m}}$

Mass of electron < mass of proton

So, electron has greater de-broglie wavelength

25.

Forward bias	Reverse bias
Positive terminal of battery is connected to p-type and negative terminal is connected to n-type semiconductor.	Positive terminal of battery is connected to n-type and negative terminal is connected to p-type semiconductor.
Depletion layer is very thin.	Depletion layer is thick
p-n junction offers very low resistance	p-n junction offers very high resistance.
An ideal diode have zero resistance	An ideal diode have infinite resistance.

OR

The required energy band diagram is shown below:

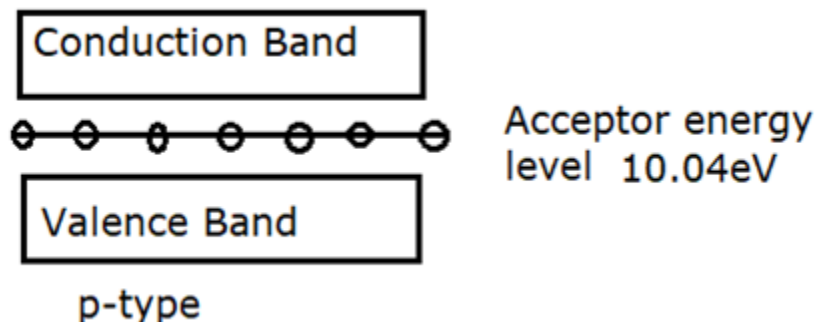

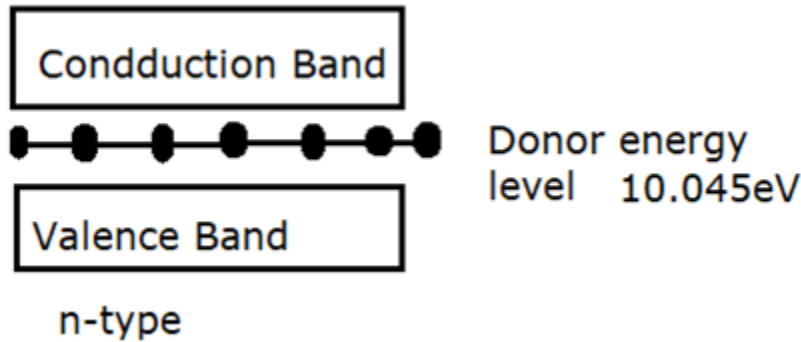

### Section D

26. (i) Each free electron accelerates due to the force that acts on it. This increases its drift speed until it collides with a positive ion of the metal. It loses some energy after each collision, but it again accelerates and then collides and once again loses some energy. This sequence of events continues. Hence, on an average, the electrons acquire only a drift speed, but they are not able to accelerate.
- (ii) In the presence of an electric field, the path of the electrons is generally curved rather than straight.

27.

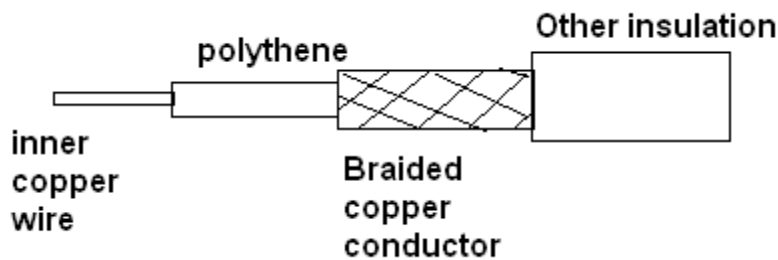

- a. A coaxial cable is as shown in the figure above. It consists of an inner conductor that is made of a copper wire, and the outer conductor can be either a solid or braided mesh of fine wires. The outer conductor is externally covered with a polymer jacket for protection.
- b. The upper limit of the frequency that can be used is 20MHz.
28. A is a capacitor and B is an inductor.  
On decreasing the frequency of the applied voltage, the inductive reactance decreases, so the current through the inductor will increase.  
For this change in the frequency, the capacitive reactance increases, so the current through the capacitor decreases.

OR

$$E = E_0 \sin \omega t$$



$$E - L \frac{dI}{dt} = 0$$

$$\frac{dI}{dt} = \frac{E}{L} = \frac{E_0}{L} \sin \omega t$$

$$I = \frac{E_0}{L} \int \sin \omega t$$

$$= -\left(\frac{E_0}{\omega L}\right) \cos \omega t = -I_0 \cos \omega t$$

$$\text{where } I_0 = \frac{E_0}{\omega L}$$

$$\text{or, } I = I_0 \sin\left(\omega t - \frac{\pi}{2}\right)$$

Hence, current lags behind the voltage by a phase angle of  $\frac{\pi}{2}$ .

29. A wire loop of area  $A$  is free to rotate about an axis which is perpendicular to a uniform magnetic field  $B$ .

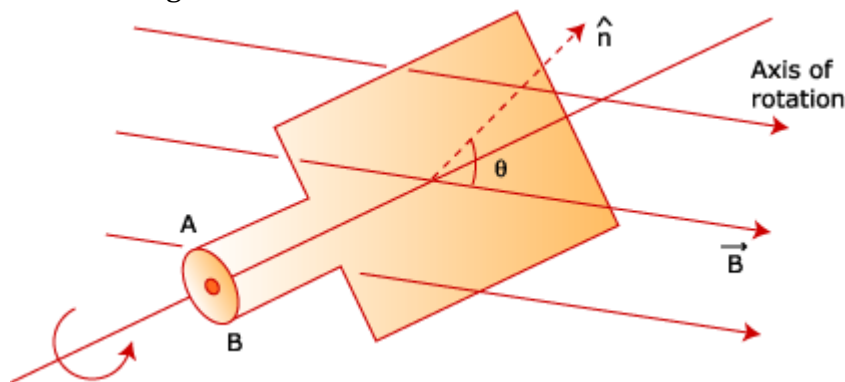

If the normal to the loop  $\hat{n}$  makes an angle  $\theta$  with  $\vec{B}$ , then the flux through the loop is  $\Phi = BA \cos \theta$ .

If this loop rotates with a constant angular velocity  $\omega = \frac{d\theta}{dt}$ , then the flux through it

changes at the rate

$$\frac{d\Phi}{dt} = -BA \sin \theta \frac{d\theta}{dt} = -BA \omega \sin(\omega t + C_0)$$

where  $C_0$  is a constant.

$\therefore$  emf is induced between ends A and B and is given by

$$\varepsilon = BA \omega \sin(\omega t + C_0)$$

$$\varepsilon = V_m \sin(\omega t + C_0)$$

$$V_m = BA \omega = \text{Peak value of emf generated.}$$

**OR**

The coil P should be moved quickly towards or away from the coil S. The laws involved here are Faraday's law of electromagnetic induction.

On the basis of his experiment, Faraday gave the following two laws.





First law: Whenever magnetic flux linked with a circuit changes, an emf is induced in it which lasts, so long as change in flux continuous

Second law: The emf induced in loop or closed circuit is directly proportional o the rate of change of magnetic flux linked with the loop

$$e = \frac{-d\phi}{dt} \text{ or } e = -N \frac{-d\phi}{dt}$$

Where, N=number of turns in the coil. Negative sign indicates lenz's law.

30. (i) Photons travel in a straight line with the speed of light.  
 (ii) Rest mass of a photon is zero or a photon cannot exist at rest.  
 (iii) The equivalent mass of a photon is  
 $E = hv = mc^2$   
 $m = hv/c^2$   
 (iv) Due to the change in wavelength, photons travel with different speeds in different media.  
 (v) Momentum of photon is  
 $p = h/\lambda$

### Section E

31. Condition: Size of the obstacle or aperture should be comparable with the wavelength of incident light.

Let a plane wave front incident on slit LM be of width 'a'. To consider diffraction effects at any point P, directed an angle  $\theta$  to the incident ray, the wave front is divided into a number of parts, with each part treated as a secondary wave front.

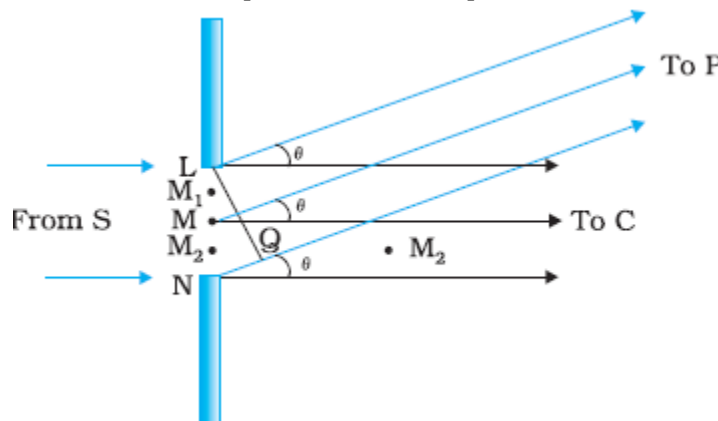

Path difference between secondary wave front from L and M =  $a \sin \theta$

For minima,  $a \sin \theta = n\lambda$

For maxima,  $a \sin \theta = (2n + 1) \frac{\lambda}{2}$

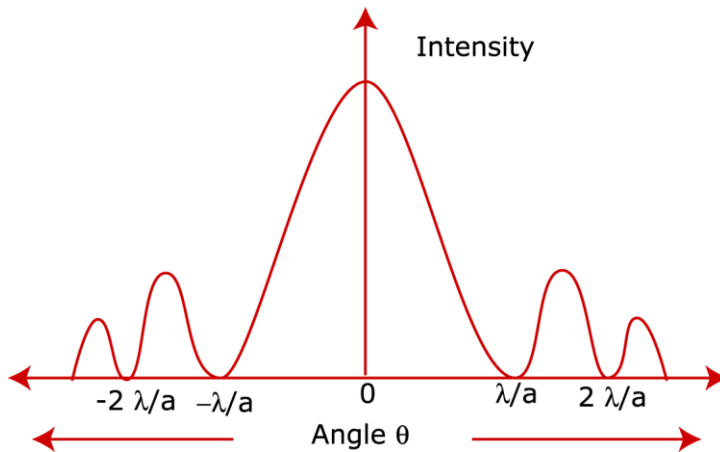

OR

Coherent sources of light: Two sources with the same frequencies having a time-independent phase difference or zero phase difference.

If the phase difference is variable, the interference term averages to zero. In case of a stable phase difference between coherent sources, the intensity at each point will vary and so sustained interference will be observed.

Difference between interference and diffraction pattern formed due to a single slit:

Interference	Diffraction
All bright and dark fringes are of equal width.	Width of secondary maxima keeps on decreasing.
At $\theta = \lambda / a$ , a bright fringe is formed.	At $\theta = \lambda / a$ , a dark fringe is formed.
Pattern is formed due to the superposition of two different wave fronts.	Pattern is formed due to the superposition of wavelets of the same wave front.

32. According to the Biot-Savart law, the magnetic field dB due to an element dl carrying a steady current I at a point P at a distance r from the current element is

$$dB = \frac{\mu_0}{4\pi} I \frac{d\ell \times r}{r^3}$$

By taking a circuit element, we can write the magnetic field due to this segment. Then integrate to find the magnetic field due to the circular current loop, which comes out to be

$$B = \frac{\mu_0 I a^2}{2(a^2 + x^2)^{3/2}}$$

The magnetic field at the centre of the coil is found by putting  $x = 0$

$$B_1 = \frac{\mu_0 I}{2a}$$

Magnetic field at an axial point for  $x = \sqrt{3}a$  is

$$B_2 = \frac{\mu_0 I}{16a}$$

$$\frac{B_1}{B_2} = 8 : 1$$

OR

A)

Let the magnetic field acting on the loop be  $B$  and length of the rod  $PQ$  be  $l$   
The induced e.m.f.  $\varepsilon = Blv$

i) Current in the loop  $i = \frac{\varepsilon}{r} = \frac{Blv}{r}$

ii) Force  $F = ilB = \frac{Blv}{r} \times lB \Rightarrow F = \frac{B^2 l^2 v}{r}$

iii) Power required to move the arm  $PQ$   $P = \varepsilon i = \frac{B^2 l^2 v^2}{r}$

B)  $\tau$  (Torque on the loop) =  $MB \sin \theta$

As  $\vec{M}$  and  $\vec{B}$  are parallel hence torque will be zero

Force acting on the loop

$$= \frac{\mu_0 I_1 I_2}{2\pi} l \left( \frac{1}{r_1} - \frac{1}{r_2} \right)$$

$$= 2 \times 10^{-7} \times 4 \times 1 \times 5 \times 10^{-2} \left( \frac{1}{10^{-2}} - \frac{1}{3 \times 10^{-2}} \right)$$

$$= 2.67 \times 10^{-6} \text{ N}$$

33. (a)

$$\beta = \frac{\Delta I_C}{\Delta I_B} = \frac{2 \text{ mA}}{20 \mu\text{A}} = 100$$

(b) Input resistance  $R_{BE} = \frac{\Delta V_{BE}}{\Delta I_B} = \frac{20 \text{ mV}}{20 \mu\text{A}} = 1 \text{ k}\Omega$

(c) Transconductance =  $\frac{\Delta I_C}{\Delta V_{BE}} = \frac{2 \text{ mA}}{20 \text{ mV}} = 0.1 \text{ mho}$

(d) Change in input voltage is  $R_L \Delta I_C = (5 \text{ k}\Omega)(2 \text{ mA}) = 10 \text{ V}$

The applied signal voltage =  $20 \text{ mV}$

Thus, voltage gain

$$= \frac{10 \text{ V}}{20 \text{ mV}} = 500 \quad (1)$$

OR

**Commonemitter transistor amplifier:** The commonemitter transistor amplifier gives the highest gain, and hence, it is the most commonly employed circuit. The figure depicts the circuit for a PNP transistor.



In this circuit, the emitter is common to both input (emitter–base) and output (collector–emitter) circuits and is grounded. The emitter–base circuit is forward biased and the base–collector circuit is reverse biased.

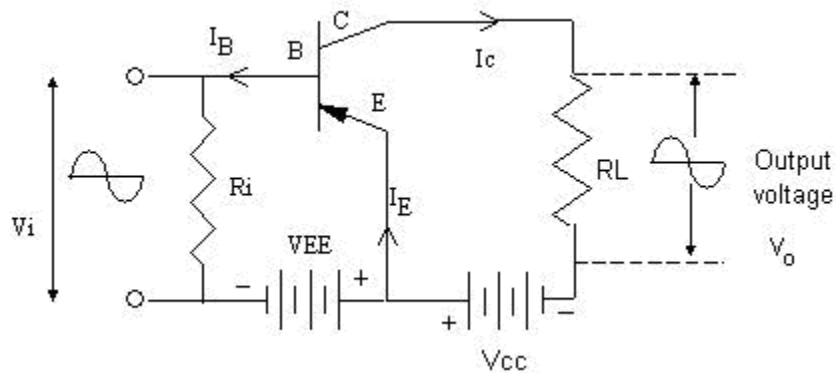

**Working principle:** In a common emitter circuit, the collector current is controlled by the base current rather than the emitter current. Since in a transistor, a large collector current corresponds to a very small base current, when the input signal is applied to the base, a very small change in the base current provides a much larger change in the collector current, and thus, extremely large current gains are possible.

**Current gain:** The ratio of the change in collector current to the change in base current is defined as the alternating current gain denoted by  $\beta$ . Thus,

$$\beta (\text{a.c.}) = \frac{\Delta I_c}{\Delta I_b}$$

$\beta$  has positive values and is generally greater than 20.

**Voltage gain:**

The voltage gain of the common emitter transistor amplifier is given by

$$A_v = \frac{\Delta V_{out}}{\Delta V_{in}} = \frac{R_L \Delta I_c}{R_i \Delta I_b} = \frac{\Delta I_c}{\Delta I_b} \cdot \frac{R_L}{R_i}$$

$$\Rightarrow A_v = \beta \frac{R_L}{R_i}$$